

Technical Specification

Design and Manufacture: BS1873 or ASME B16.34

Inspection and Test: API 598

End flange dimension: ASME B16.5

BW end dimension: ASME B16.25

Socket-weld dimension: ASME B16.11

Face to face and end to end: ASME B16.10

Pressure-temperature ratings: ASME B16.34

Form of Major Part Material

Parts No.	Parts Name	Materials				
		WCB/Trim 1	WCB/Trim 5	WCB/Trim 8	CF8/304	CF8M/316
1	Body	ASTM A216 WCB	ASTM A216 WCB	ASTM A216 WCB	ASTM A351 CF8	ASTM A351 CF8M
2	Seat ring	A105 + 13Cr	A105 + STL	A105 + STL	ASTM A351 CF8	ASTM A351 CF8M
3	Disc	ASTM A216 WCB + 13Cr	ASTM A216 WCB + STL	ASTM A216 WCB + 13Cr	ASTM A351 CF8	ASTM A351 CF8M
4	Stem	ASTM A182 F6a	ASTM A182 F6a	ASTM A182 F6a	ASTM A182 F304	ASTM A182 F316
5	Disc nut	ASTM A216 WCB	ASTM A216 WCB	ASTM A216 WCB	ASTM A351 CF8	ASTM A351 CF8M
6	Bonnet nut	ASTM A194 2H	ASTM A194 2H	ASTM A194 2H	ASTM A194 8	ASTM A194 8M
7	Bonnet bolt	ASTM A193 B7	ASTM A193 B7	ASTM A193 B7	ASTM A193 B8	ASTM A193 B8M
8	Gasket	304 sheet + Graphite	304 sheet + Graphite	304 sheet + Graphite	304 + Graphite	316 + Graphite
9	Backseat bushing	ASTM A182 F6a	ASTM A182 F6a	ASTM A182 F6a	ASTM A351 CF8	ASTM A351 CF8M
10	Bonnet	ASTM A216 WCB	ASTM A216 WCB	ASTM A216 WCB	ASTM A351 CF8	ASTM A351 CF8M
11	Packing	Graphite	Graphite	Graphite	Graphite	Graphite
12	Eyebolt pin	ASTM A36	ASTM A36	ASTM A36	304ss	316ss
13	Gland eyebolt	ASTM A193 B7	ASTM A193 B7	ASTM A193 B7	ASTM A193 B8	ASTM A193 B8M
14	Gland	ASTM A182 F6a	ASTM A182 F6a	ASTM A182 F6a	ASTM A182 F304	ASTM A182 F316
15	Gland flange	ASTM A216 WCB	ASTM A216 WCB	ASTM A216 WCB	ASTM A351 CF8	ASTM A351 CF8M
16	Eyebolt nut	ASTM A194 2H	ASTM A194 2H	ASTM A194 2H	ASTM A194 8	ASTM A194 8M
17	Stem nut	ASTM A439 D2	ASTM A439 D2	ASTM A439 D2	ASTM A439 D2	ASTM A439 D2
18	Hand wheel	Ductile Iron	Ductile Iron	Ductile Iron	Ductile Iron	Ductile Iron
19	Hand wheel nut	Carbon steel	Carbon steel	Carbon steel	Carbon steel	Carbon steel

Note: The chart above only lists out some common composition of steel check valve parts. We may provide other different parts material composition according to the customer's request or the actual valve working condition.

Cast Steel Globe Valve Class 150

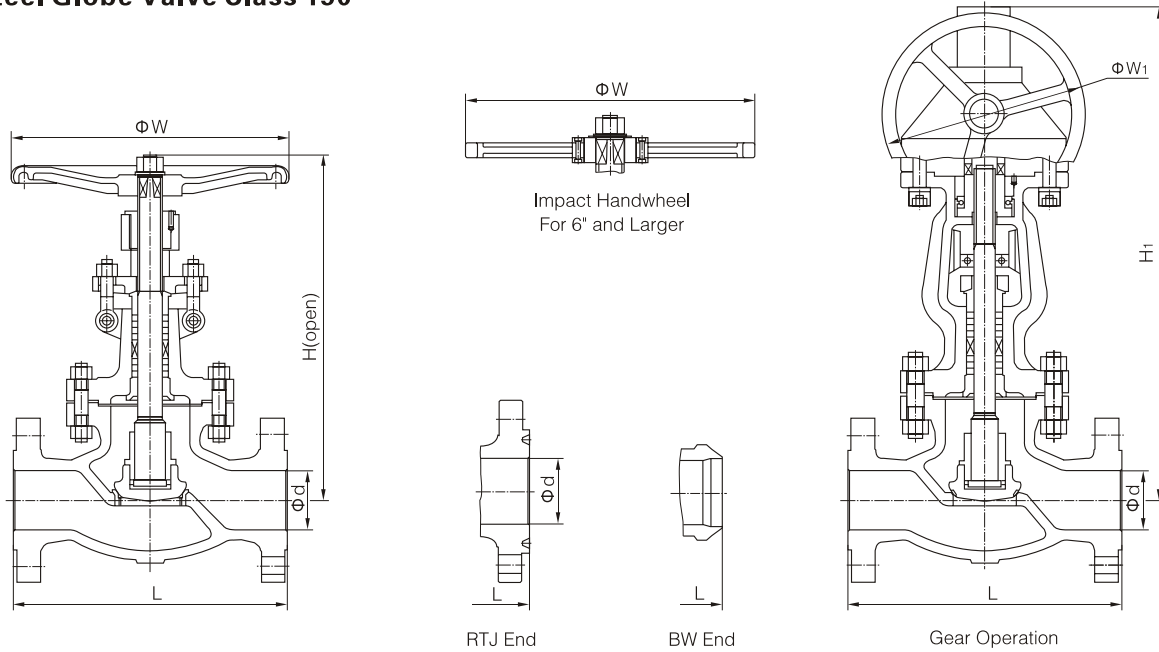

Class	Size		Dimensions(mm)								Weight(kg)	
	NPS	DN	L			d	H	H ₁	W	W ₁	H.W	G.O
			RF	RTJ	BW							
150	1/2	15	108	119	108	13	182	-	100	-	4	-
	3/4	20	117	130	117	19	193	-	100	-	6	-
	1	25	127	140	127	25	217	-	100	-	8	-
	1 1/4	32	140	152	140	32	235	-	135	-	12	-
	1 1/2	40	165	178	165	38	258	-	135	-	16	-
	2	50	203	216	203	51	330	-	200	-	25	-
	2 1/2	65	216	229	216	64	360	-	250	-	42	-
	3	80	241	254	241	76	390	-	280	-	46	-
	4	100	292	305	292	102	445	-	300	-	74	-
	5	125	356	369	356	127	480	-	350	-	111	-
	6	150	406	419	406	152	520	556	350	310	165	258
	8	200	495	508	495	203	600	658	400	310	275	300
10	250	622	635	622	254	773	805	450	460	400	450	
12	300	698	711	698	305	880	955	500	460	624	725	

Cast Steel Globe Valve Class 300

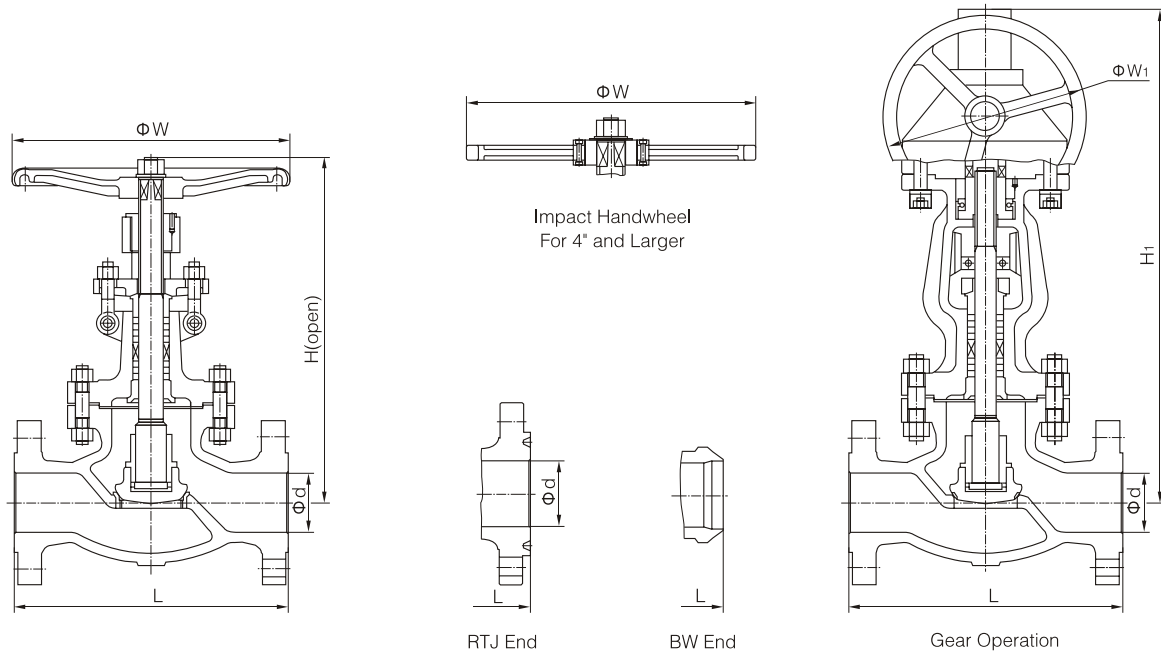

Class	Size		Dimensions(mm)								Weight(kg)	
	NPS	DN	L			d	H	H ₁	W	W ₁	H.W	G.O
			RF	RTJ	BW							
300	1/2	15	152	164	152	14	185	-	100	-	5	-
	3/4	20	178	191	178	19	195	-	100	-	7	-
	1	25	203	216	203	25	220	-	135	-	10	-
	1 1/4	32	216	229	216	32	240	-	135	-	14	-
	1 1/2	40	229	241	229	38	260	-	160	-	19	-
	2	50	267	283	267	51	385	-	200	-	25	-
	2 1/2	65	292	308	292	64	420	-	200	-	42	-
	3	80	318	333	318	76	440	-	280	-	46	-
	4	100	356	371	356	102	515	-	350	-	74	-
	5	125	400	416	400	127	580	-	350	-	111	-
	6	150	444	460	444	152	660	690	400	310	165	195
	8	200	559	575	559	203	900	950	550	460	275	327
10	250	622	638	622	254	950	990	600	460	400	452	
12	300	711	727	711	305	1030	1080	700	460	624	725	

Cast Steel Globe Valve Class 600/900

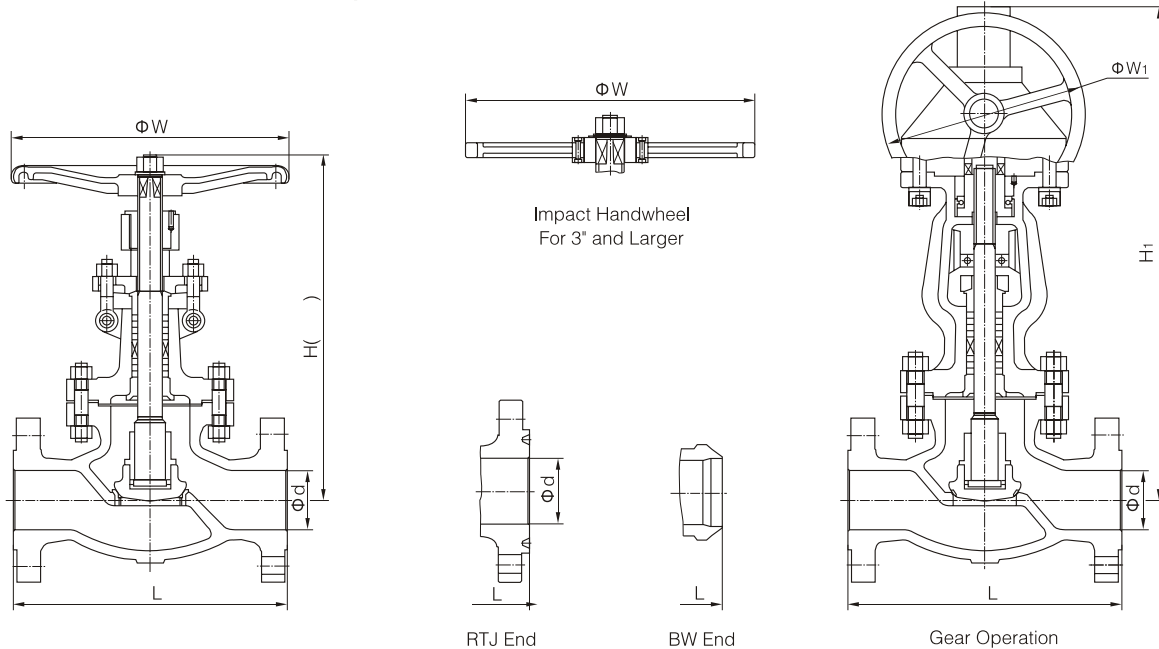

Class	Size		Dimensions(mm)								Weight(kg)	
	NPS	DN	L			d	H	H ₁	W	W ₁	H.W	G.O
			RF	RTJ	BW							
600	2	50	292	295	292	51	360	-	250	-	32	-
	2 1/2	65	330	333	330	64	410	-	280	-	42	-
	3	80	356	359	356	76	465	-	300	-	63	-
	4	100	432	435	432	102	545	575	400	310	107	138
	5	125	508	511	508	127	625	660	500	310	185	215
	6	150	559	562	559	152	785	820	550	460	290	342
900	2	50	368	371	368	51	480	-	350	-	55	-
	2 1/2	65	419	422	419	64	520	-	350	-	68	-
	3	80	381	384	381	76	564	630	400	310	95	128
	4	100	457	460	457	102	685	720	450	310	160	210
	5	125	559	562	559	127	780	840	550	460	270	325
	6	150	610	613	610	152	950	1015	650	460	410	480